



SCREWTECH[®]

LINEAR MOTION SYSTEMS & SOLUTIONS

PRECISION BALL SCREW



PRODUCT MANUAL

SCREW TECHNOLOGY CO.,LTD.

Transmission parts and supporting mechanical parts.
Linear transmission components, such as single-axis and multi-axis components.
Motors, controllers, sensors, encoders, etc.
Design, assembly and debugging of non-standard automation equipment, etc.

-  Professional Customization
-  Precision Machining
-  High Quality Assurance



<http://www.screw-tech.com/>



MAIN PRODUCTS

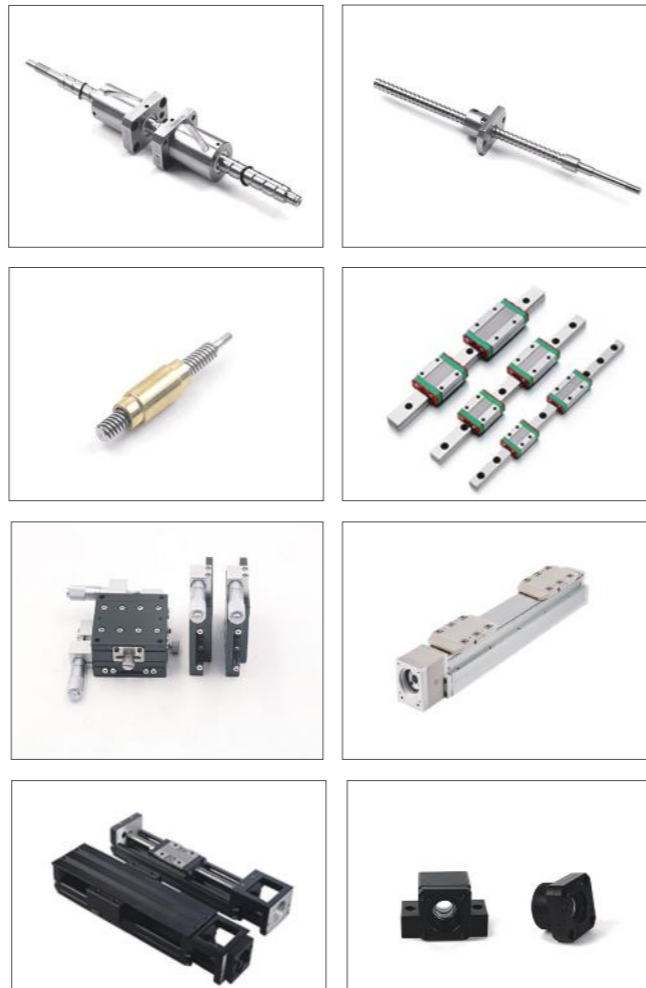

ABOUT US

We SCREW TECHNOLOGY CO., LIMITED is established in 2011, is a manufacturer of linear motion systems. We committed to providing customers with linear motion solutions. Adhering to the business philosophy of "professional, integrity, and efficiency", we look forward to contributing to the world's automated manufacturing.

Our products include:

- ▶ Transmission parts and supporting mechanical parts, such as: ball screw and lead screw, guide rail, ball spline, coupling, support unit, nut seat, motor house, adapter plate, bearing, etc.;
- ▶ Linear transmission components, such as: single axis robot, multi-axis linear modules, electric cylinders, and linear platforms;
- ▶ Motors, controllers, sensors, encoders, etc., such as: stepper motors, servo motors, drivers, etc.;
- ▶ Design, assembly and debugging of non-standard automation equipment.

Catalog



01

Precision Ball Screw Selection Guide

Precision Ball Screw Characteristic	004
Lead precision and clearance of ball screw	005
Ball screw runout and position tolerance	007
Precautions for the selection and use of ball screw	010

02

Precision Grinding Series

SFI Precision Grinding Series	011
SFU Precision Grinding Series	012
SFH Precision Grinding Series	013
SFY Precision Grinding Series	014
SFS Precision Grinding Series	015
DFS Precision Grinding Series	016
SFV Precision Grinding Series	017
DFV Precision Grinding Series	018
SFI Precision Grinding Series	019
DFI Precision Grinding Series	020
DFU Precision Grinding Series	021
SFK Precision Grinding Series	022
SCI Precision Grinding Series	023
BSH Precision Grinding Series	024

03

Grinding shaft end

Grinding shaft end	025
--------------------------	-----

Ball Screw Introduction

Ball screw is a high-precision mechanical transmission component composed of screw, nut, steel ball, sealing ring and other parts. It is widely used in various industrial automation equipment, precision instruments, precision CNC machine tools, etc

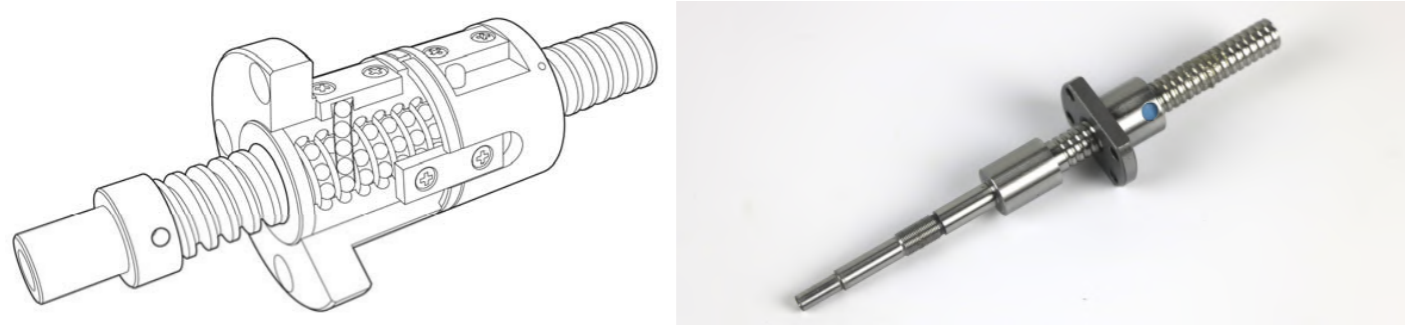

Ball Screw Basic Shape

Ball Screw Characteristics

High Transmission Efficiency

Transmission efficiency of ball screw is as high as 90% or more, which is 2-4 times of lead screw. Therefore, larger thrust can be obtained with a smaller torque, and it can also be converted from linear motion to rotary motion (movement is reversible).

Operating Smoothly

Ball screw is a point contact rolling motion, with low frictional resistance and high sensitivity during work, no chattering when starting, and no creeping phenomenon at low speed, so precise micro-feeding can be realized. On the other hand, due to the high efficiency and low heat generation of ball screw, high-speed feeding is possible.

High Precision

The temperature rise of the ball screw is small during operation, and it can be pre-tightened to eliminate the axial gap and pre-stretch the screw to compensate for thermal extension, so higher positioning precision and repeat positioning precision can be obtained.

High Durability

The surface of the ball screw and nut has been hardened (HRC58-62) treatment and accurate grinding. At the same time, Ball screw is driven by rolling of balls, the relative wear is extremely small, so it has a longer service life and higher precision retaining ability.

Good Synchronization

Due to the smooth movement, sensitive response, no blockage, and no sliding, a good synchronization effect can be obtained when multiple sets of the same ball screw are used to simultaneously transmit one or more of the same components or equipments.

High Reliability

Compared with other transmission machinery and hydraulic transmission, the failure rate of the ball screw is very low, and the maintenance is simple. It only requires general lubrication and dust prevention, and it can work in many special occasions and environments.

Without Gap and Preload

Ball screw adopts Gothic groove shape, and the axial clearance can be adjusted very small. If the proper pre-tightening load is added to eliminate the axial gap, ball screw can have better rigidity, reduce the elastic deformation between the balls, nut and screw during load, and achieve higher precision.

Ball screw lead precision

Lead precision of precision ball screw is implemented in "GB T 17587.1-1998" and "JIS B 1192:1997"

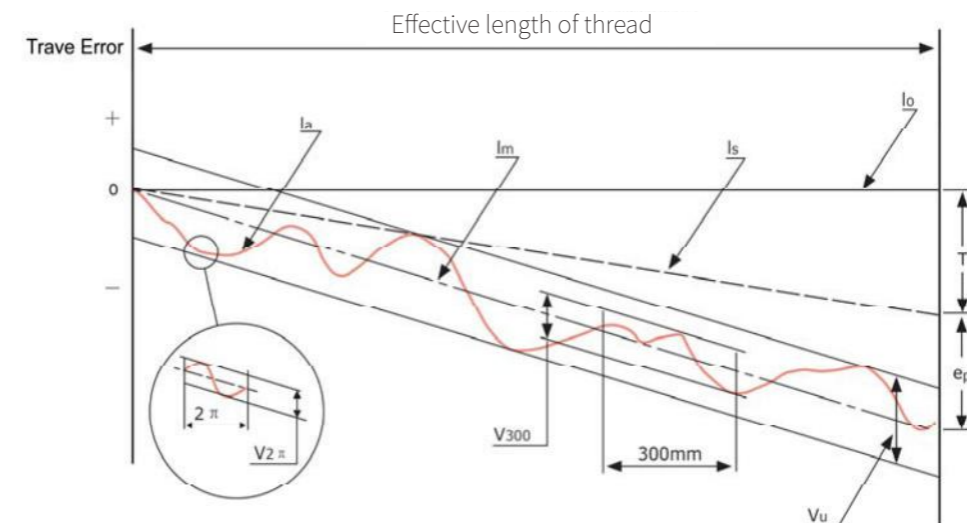

Cumulative nominal lead deviation (e_p)	The maximum deviation of the cumulative nominal lead in the effective stroke.
Lead deviation (V_u)	Maximum variation range of the allowable lead within the effective stroke.
Lead deviation ($V_{2\pi}$)	Lead variation value for any one revolution.
Lead deviation (V_{300})	Any 300mm allowable maximum range of lead change within the effective stroke

Ball screw application type and precision level

Type	Symbol	Precision level	Note
Position purpose	C	0, 1, 3, 5	JIS standard
	Cp	1, 3, 5	Equivalent to the ISO
Transmission purpose	Ct	1, 3, 5, 7, 10	

Ball screw actual average stroke deviation ($\pm ep$) allowable error

Precision level		C0		C1		C3		C5		Cp1		Cp3		Cp5			
$V2\pi$		3		4		6		8		4		6		8			
V300		3.5		5		8		18		6		12		23			
Effective thread length (lu)		ep		Vu		ep		Vu		ep		Vu		ep		Vu	
More	Below																
-	315	4	3.5	6	5	12	8	23	18	6	6	12	12	23	23		
315	400	5	3.5	7	5	13	10	25	20	7	6	13	12	25	25		
400	500	6	4	8	5	15	10	27	20	8	7	15	13	27	26		
500	630	6	4	9	6	16	12	30	23	9	7	16	14	32	29		
630	630	7	5	10	7	18	13	35	25	10	8	18	16	36	31		
630	1000	8	6	11	8	21	15	40	27	11	9	21	17	40	34		
1000	1250	9	6	13	9	24	16	46	30	13	10	24	19	47	39		
1250	1600	11	7	15	10	29	18	54	35	15	11	29	22	55	44		
1600	2000	/	/	18	11	35	21	65	35	18	13	35	25	65	51		
2000	2500	/	/	22	13	41	24	77	46	22	15	41	29	78	59		
2500	3150	/	/	26	15	50	29	93	54	26	17	50	34	96	69		
3150	4000	/	/	30	18	60	29	115	65	32	21	62	41	115	82		
4000	5000	/	/	/	/	72	41	140	77	/	/	76	49	140	99		
5000	6300	/	/	/	/	90	50	170	93	/	/	/	/	170	119		
6300	8000	/	/	/	/	110	60	210	115	/	/	/	/	/	/		
8000	10000	/	/	/	/	/	/	260	140	/	/	/	/	/	/		
10000	12000	/	/	/	/	/	/	320	170	/	/	/	/	/	/		

Ball screw runout and position tolerance

All measurements are made according to DIN 69051 and JIS B1192.

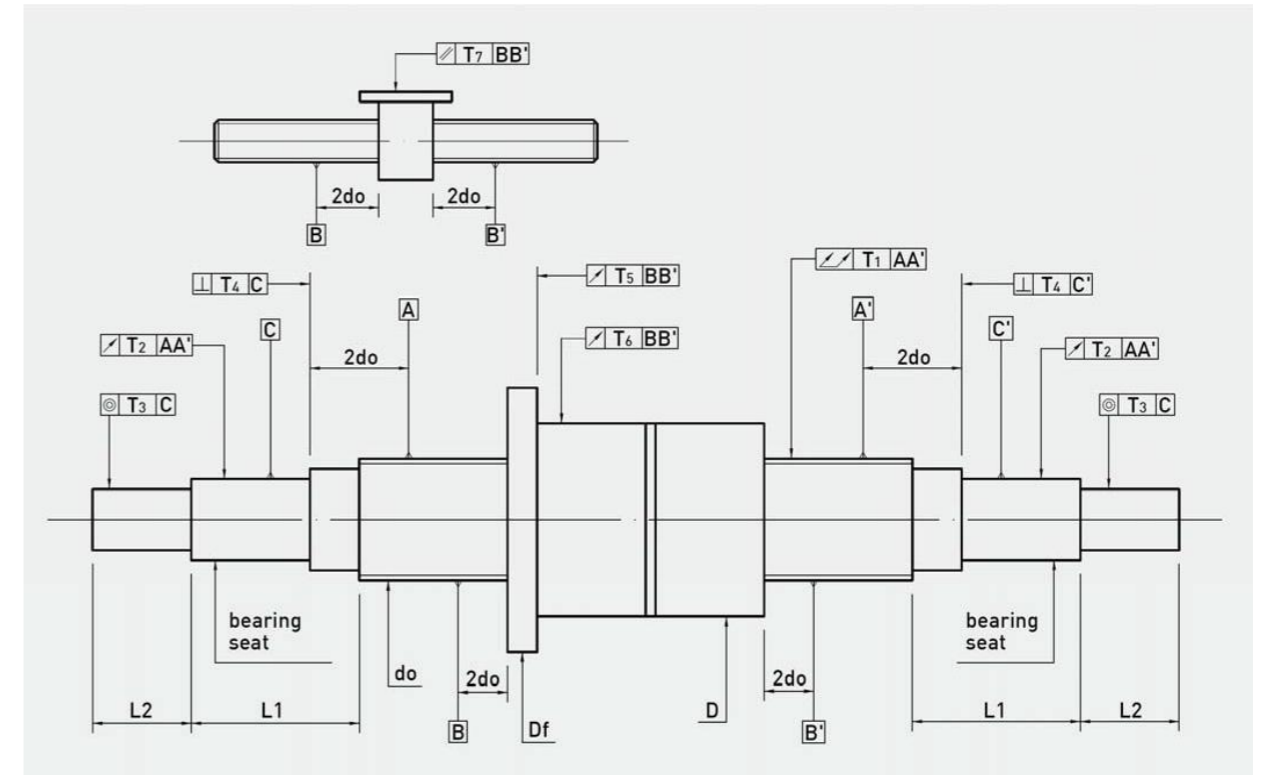

The radial runout of the outer diameter of the ball screw per L_t length affects the end face runout of AA' (only for ball nuts with preload)

Nominal diameter d_o (mm)		Reference length	T1P (μm)			
以下	以上	L_5	Cp1, Ct1	Cp3, Ct3	Cp5, Ct5	Ct7
6	12	80	20	25	32	40
12	25	160				
25	50	315				
50	100	630				
100	200	1250				

L/D (L_t/d_o)		T1MAX (μm) (apply to $L_t \geq 4L_5$)			
Below	Above	Cp1, Ct1	Cp3, Ct3	Cp5, Ct5	Ct7
-	40	40	50	64	80
40	60	60	75	96	120
60	80	100	125	160	200
80	100	160	200	256	320

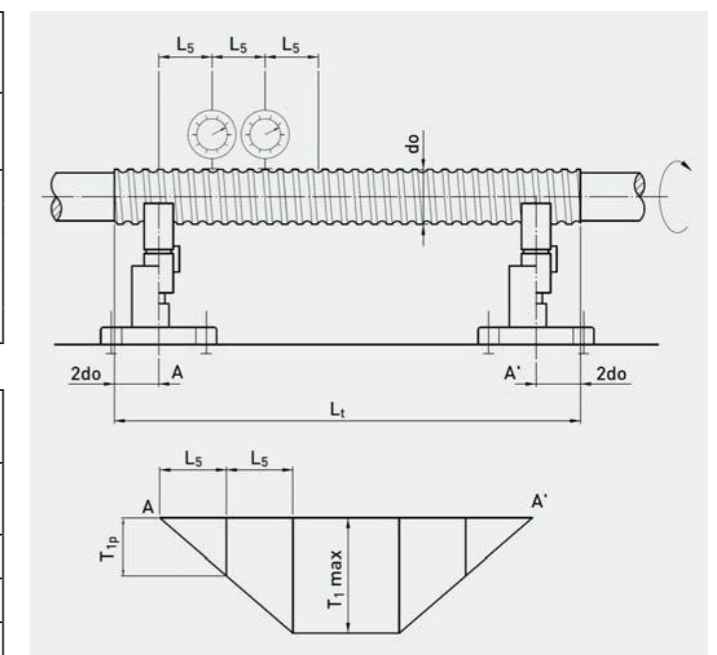
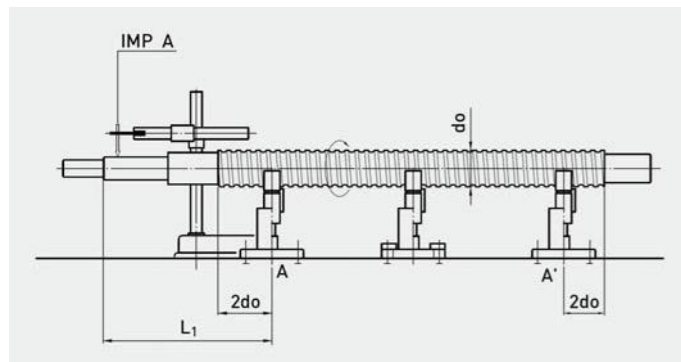

Fig. T1

Radial runout between the outer diameter of the positioning screw and the axis of the supporting part.

Precision		C0					C1					C3					C5												
Nominal diameter do(mm)	Below	-	8	12	20	32	50	-	8	12	20	32	50	80	-	8	12	20	32	50	80	125	-	8	12	20	32	50	80
	Containing or above	8	12	20	32	50	80	8	12	20	32	50	80	125	8	12	20	32	50	80	125	8	12	20	32	50	80	125	
Thread length	以下	15	15	15			20	20	15					25	25	20					35	35	35						
	125	25	20	20	15		35	25	20	15				35	35	25	20				50	40	40	35					
	200	315	35	25	20	20		40	30	25	20			50	40	30	30				65	55	45	40					
	315	400		35	25	20	15	45	40	30	25	20		60	50	40	35	25			75	65	55	45	35				
	400	500		45	35	25	20		50	35	30	25		65	50	40	30				80	60	50	45					
	500	630		50	40	30	20	15	60	40	35	25	20		70	55	45	35	30		90	75	60	50	40				
	630	800		50	35	25	20		55	40	30	25		70	55	40	35				90	70	55	45					
	800	1000		65	45	30	25		65	55	40	30	25		95	65	50	40	30		120	85	65	50	45				
	1000	1250		85	55	40	30		85	65	45	35	30		120	85	60	45	35		150	100	75	60	50				
	1250	1600		110	70	50	40		120	85	60	45	35		160	110	75	55	40		190	130	95	70	55				
	1600	2000		95	65	45			120	80	55	40			140	95	70	50			170	120	85	65					
	2000	2500														100	70	50					150	110	80				
	2500	3150														130	90	60					200	140	95				
	3150	4000															120	80					260	180	120				
	4000	5000																						240	160				
5000	6300																									210			
6300	8000																									280			
8000	10000																									370			

Item	Perpendicularity tolerance (Max)				Perpendicularity tolerance (Max)				Parallelism tolerance (Max)						
	Nut flange diameter Df (mm)		T5P (μm)		T6P (μm)		T7P (μm)		Length						
Measurement mode	Fig. T5				Fig. T6				Fig. T7						
	Below	Above	C0	C1	C3	C5	C0	C1	C3	C5	Below	Above	C0	C1	C3
-	20	5	6	8	10	5	6	9	12	-	50	5	6	8	10
20	32	5	6	8	10	6	7	10	12	-	50	5	6	8	10
32	50	6	7	8	11	7	8	12	15	-	50	5	6	8	10
50	80	7	8	10	13	8	10	15	19	50	100	7	8	10	13
80	125	7	9	12	15	9	12	20	27	50	100	7	8	10	13
125	160	8	10	13	17	10	13	22	30	50	100	7	8	10	13
160	200	-	11	14	18	-	16	25	34	100	200	-	10	13	17
200	250	-	12	15	20	-	18	28	38	100	200	-	10	13	17



Radial runout of bearing position to AA' end face

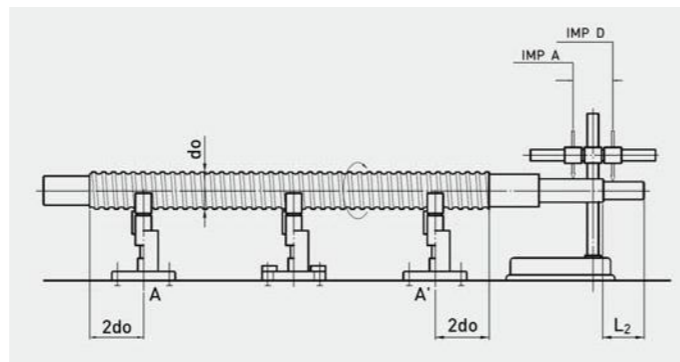

Radial runout of bearing position to AA' end face

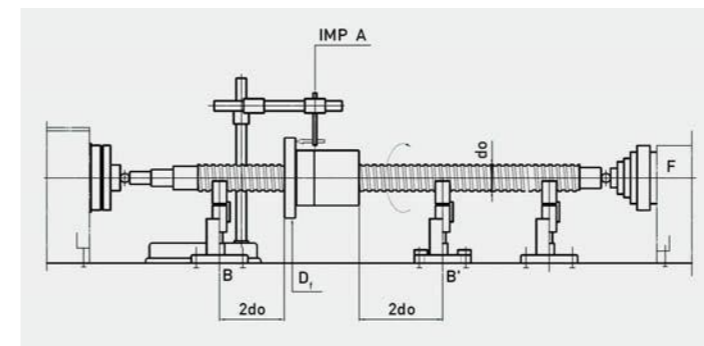

Axial runout of ball nut mounting end facing to AA' end

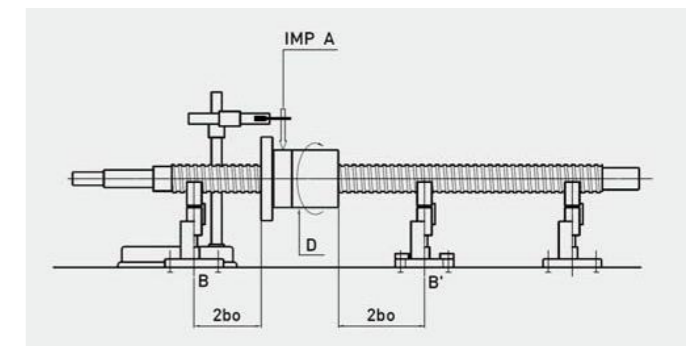

Axial runout of ball nut installation diameter to AA' end

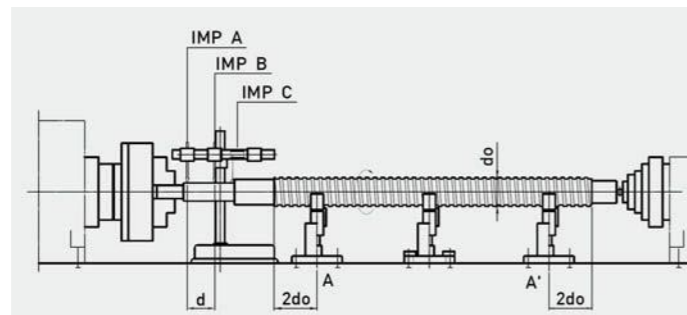

Radial runout of bearing position to AA' end face

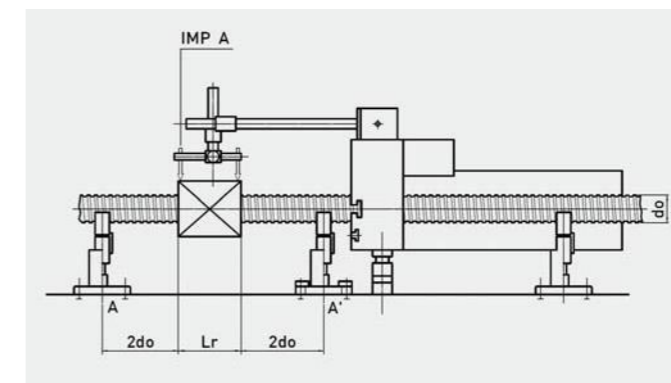

Parallelism of rectangular ball nut to AA'

Determine preload

In order to improve transmission precision and rigidity of ball screw, it is necessary to apply a pre-tightening force to the screw. After applying the preload, friction torque and working temperature rise increase. Therefore, it is necessary to determine the appropriate pre-tightening force (maximum 10% of the rated dynamic load) to obtain the best working life and the lowest temperature rise effect while meeting the precision and rigidity requirements.

Lubrication

Ball screw must have sufficient lubrication when used, otherwise it will increase friction and wear, leading to failure and shortening the service life. Oil lubrication: Please refer to the table below for the relubrication amount and interval of oil lubrication. According to the oil amount in the table, at least the relubrication time of 8 hours working time can be achieved.

Nominal diameter	First lubrication amount (ml)	Relubrication amount (ml/8h)
16	0.3	0.05
20	0.6	0.08
25	0.8	0.1
32	1.0	0.2
40	2.0	0.5
50	4.0	1.0
63	4.0	1.0
80	6.0	1.5
100	10.0	2.0

Grease lubrication

The advantage of using grease is that it can shorten the time for replenishing grease. The limit of replenishing grease is about half of the volume of the nut space. All high-grade ball bearing greases can be used, but pay attention to the instructions and tips of the grease manufacturer. Our company has injected specific grease when supplying, and users can use it directly. Grease is usually replaced in half a year or a year. The old grease should be removed before replacement.

Dust prevention

Like rolling bearings, dirt and foreign matter (cutting debris) entering the ball screw will accelerate wear and cause damage. Therefore, it is necessary to use protective devices to completely protect ball screw. In addition, it is necessary to use a wiper dust ring at both ends of the nut to prevent floating dust from entering. Our company has installed a dust-proof ring when supplying (customers can give special instructions if they don't need it).

Attention to design and use

Ball screw has no self-locking performance. Anti-reversal devices such as brake motors and stepping motors can be used, or selflocking mechanisms (such as worm gears) can be installed in the transmission system. Or set a one-way clutch, two-directional clutch, brake, etc. in the nut, screw or transmission system. When ball screw is used vertically, it is necessary to prevent the nut from falling out. The safety device to prevent the nut from falling out must be considered in the design.

Installation

Unless you really need, do not remove the nut from the screw by yourself. If you really need to remove the nut, you need to use an installation auxiliary sleeve that is 0.2 ~ 0.3mm smaller than the bottom diameter of the screw. Push the installation auxiliary sleeve to the starting end surface of the thread, screw the nut onto the auxiliary sleeve from the screw rod, and carefully remove the nut and sleeve together. Be careful not to scatter the balls. The installation sequence is opposite to the removal sequence. Care must be taken, otherwise the nut, screw or other internal parts may be damaged or fall off, causing premature failure of the ball screw transmission system.

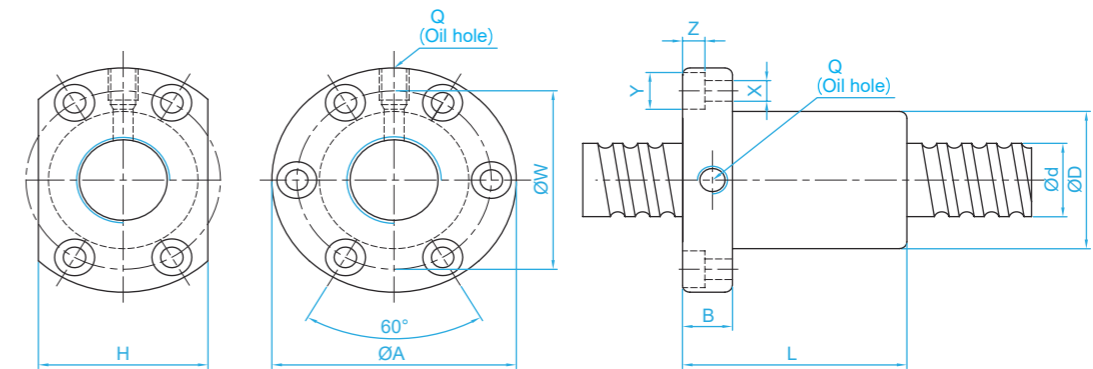

Model	Nominal diameter	Lead	Diameter	Nut size											Rated load (Kgf)		Rigidity (Kgf/μm)
				D	A	B	L	W	H	X	Y	Z	Q	n	Ca	Coa	
SFI1605-4	16	5	3.175	30	49	10	45	39	34	4.5	8	4.5	M6	1x4	1380	3052	33
SFI1605-3		10	3.175	34	58	10	57	45	34	5.5	9.5	5.5	M6	1x3	1103	2401	27
SFI2005-4	20	5	3.175	34	57	11	51	45	40	5.5	9.5	5.5	M6	1x4	1551	3875	39
SFI2505-4	25	5	3.175	40	63	11	51	51	46	5.5	9.5	5.5	M8	1x4	1724	4904	45
SFI2510-4		10	4.762	46	72	12	80	58	52	6.5	11	6.5	M6	1x4	2954	7295	51
SFI3205-4	32	5	3.175	46	72	12	52	58	52	6.5	11	6.5	M8	1x4	1922	6343	52
SFI3210-4		10	6.35	54	88	15	85	70	62	9	14	8.5	M8	1x4	4805	12208	62
SFI4005-4	40	5	3.175	56	90	15	55	72	64	9	14	8.5	M8	1x4	2110	7988	59
SFI4010-4		10	6.35	62	104	18	88	82	70	11	17.5	11	M8	1x4	5399	15500	72
SFI5010-4	50	10	6.35	72	114	18	88	92	82	11	17.5	11	M8	1x4	6004	19614	83
SFI6310-4	63	10	6.35	85	131	22	93	107	95	14	20	13	M8	1x4	6719	25358	95
SFI8010-4	80	10	6.35	105	150	22	93	127	115	14	20	13	M8	1x4	7346	31953	109

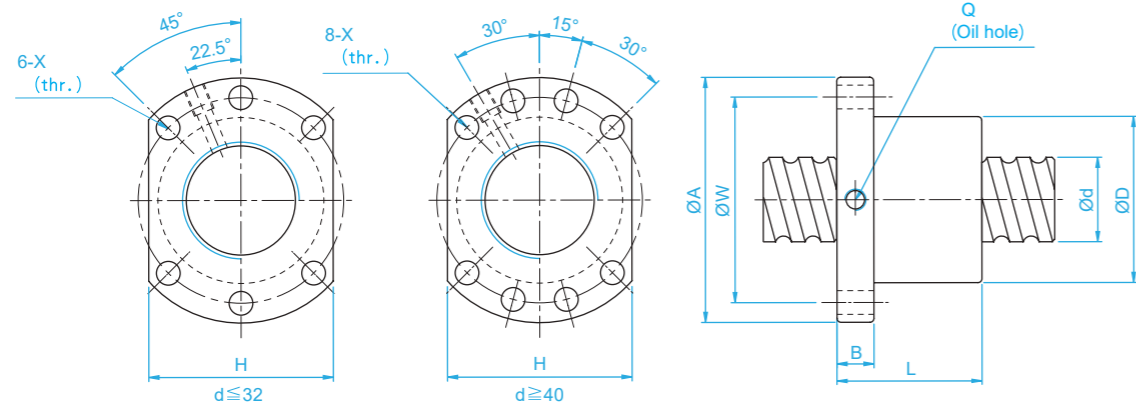

Model	Nominal diameter	Lead	Ball diameter	Nut size									Rated load (Kgf)		Rigidity (Kgf/μm)
				D	A	B	L	W	H	X	Q	n	Ca	Coa	
SFU1204-4	12	4	2.5	24	40	10	40	32	30	4.5		1x4	902	1884	26
SFU1604-4	16	4	2.381	28	48	10	40	38	40	5.5	M6	1x4	973	2406	32
SFU1605-4		5	3.175	28	48	10	45	38	40	5.5	M6	1x4	1380	3052	32
SFU1605-3		10	3.175	28	48	10	57	38	40	5.5	M6	1x3	1103	2401	26
SFU2005-4	20	5	3.175	36	58	10	51	47	44	6.6	M6	1x4	1551	3875	39
SFU2505-4	25	5	3.175	40	62	10	51	51	48	6.6	M6	1x4	1724	4904	45
SFU2510-4		10	4.762	40	62	12	80	51	48	6.6	M6	1x4	2954	7295	50
SFU3205-4	32	5	3.175	50	80	12	52	65	62	9	M6	1x4	1922	6343	54
SFU3210-4		10	6.35	50	80	12	85	65	62	9	M6	1x4	4805	12208	61
SFU4005-4	40	5	3.175	63	93	14	55	78	70	9	M8	1x4	2110	7988	63
SFU4010-4		10	6.35	63	93	14	88	78	70	9	M8	1x4	5399	15500	73
SFU5010-4	50	10	6.35	75	110	16	88	93	85	11	M8	1x4	6004	19614	85
SFU6310-4	63	10	6.35	90	125	18	93	108	95	11	M8	1x4	6719	25358	99
SFU8010-4	80	10	6.35	105	145	20	93	125	110	13.5	M8	1x4	7346	31953	109

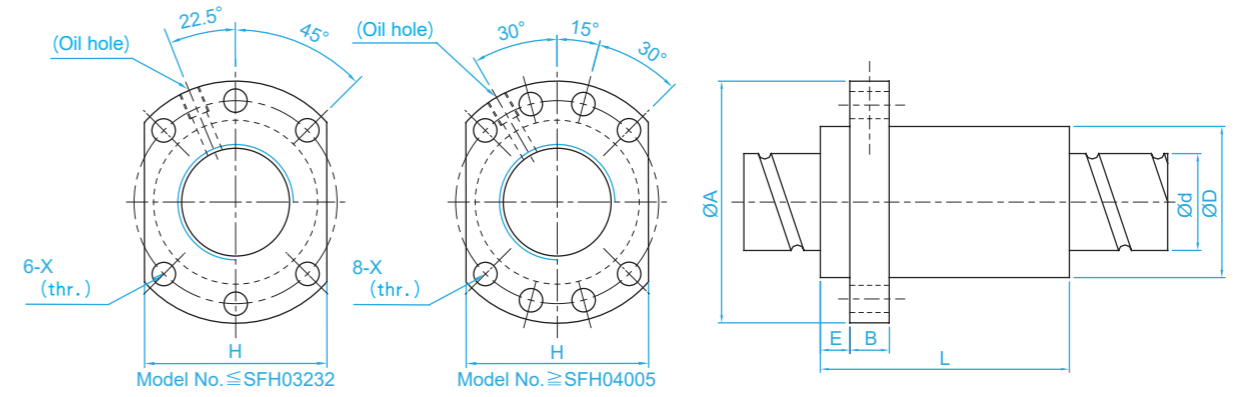

Model	Nominal diameter	Lead	Ball diameter	Nut size									Rated load (Kgf)		Rigidity (Kgf/μm)	
				D	A	E	B	L	W	H	X	Q	n	Ca		Coa
SFH1205-2.8	12	5	2.5	24	40	5	10	30	32	30	4.5		2.8x1	661	1316	19
SFH1210-2.8		10	2.5	24	40	5	10	45	32	30	4.5		2.8x1	642	1287	19
SFH1605-3.8	15	5	2.778	28	48	5	10	37	38	40	5.5	M6	3.8x1	1112	2507	20
SFH1610-2.8		10	2.778	28	48	5	10	45	38	40	5.5	M6	2.8x1	839	1821	23
SFH1616-1.8		16	2.778	28	48	5	10	45	38	40	5.5	M6	1.8x1	552	1137	14
SFH1616-2.8		16	2.778	28	48	5	10	61	38	40	5.5	M6	2.8x1	808	1769	22
SFH1620-1.8	20	20	2.778	28	48	5	10	58	38	40	5.5	M6	1.8x1	554	1170	14
SFH2005-3.8		5	3.175	36	58	7	10	37	47	44	6.6	M6	3.8x1	1484	3681	37
SFH2010-3.8		10	3.175	36	58	7	10	55	47	44	6.6	M6	3.8x1	1516	3833	40
SFH2020-1.8		20	3.175	36	58	7	10	54	47	44	6.6	M6	1.8x1	764	1758	19
SFH2020-2.8	25	20	3.175	36	58	7	10	74	47	44	6.6	M6	2.8x1	1118	2734	29
SFH2505-3.8		5	3.175	40	62	7	10	37	51	48	6.6	M6	3.8x1	1650	4658	43
SFH2510-3.8		10	3.175	40	62	7	12	55	51	48	6.6	M6	3.8x1	1638	4633	45
SFH2525-1.8		25	3.175	40	62	7	12	64	51	48	6.6	M6	1.8x1	843	2199	22
SFH2525-2.8	32	25	3.175	40	62	7	12	89	51	48	6.6	M6	2.8x1	1232	3421	34
SFH3205-3.8		5	3.175	50	80	9	12	37	65	62	9	M6	3.8x1	1839	6026	51
SFH3210-3.8		10	3.969	50	80	9	12	57	65	62	9	M6	3.8x1	2460	7255	55
SFH3220-2.8		20	3.969	50	80	9	12	76	65	62	9	M6	2.8x1	1907	5482	43
SFH3232-1.8	31	32	3.969	50	80	9	12	80	65	62	9	M6	1.8x1	1257	3426	27
SFH3232-2.8		32	3.969	50	80	9	12	112	65	62	9	M6	2.8x1	1838	5329	42
SFH4005-3.8	40	5	3.175	63	93	9	15	42	78	70	9	M8	3.8x1	2018	7589	60
SFH4010-3.8		10	6.35	63	93	9	14	60	78	70	9	M8	3.8x1	5035	13943	67
SFH4020-2.8		20	6.35	63	93	9	14	80	78	70	9	M8	2.8x1	3959	10715	54
SFH4040-1.8		40	6.35	63	93	9	14	98	78	70	9	M8	1.8x1	2585	6648	34
SFH4040-2.8	50	40	6.35	63	93	9	14	138	78	70	9	M8	2.8x1	3780	10341	52
SFH5005-3.8		5	3.175	75	110	10.5	15	42	93	85	11	M8	3.8x1	2207	9542	68
SFH5010-3.8		10	6.35	75	110	10.5	18	60	93	85	11	M8	3.8x1	5638	17852	79
SFH5020-3.8		20	6.35	75	110	10.5	18	100	93	85	11	M8	3.8x1	5749	18485	87
SFH5050-1.8	48	50	6.35	75	110	10.5	18	120	93	85	11	M8	1.8x1	2946	8749	42
SFH5050-2.8		50	6.35	75	110	10.5	18	170	93	85	11	M8	2.8x1	4308	13610	65

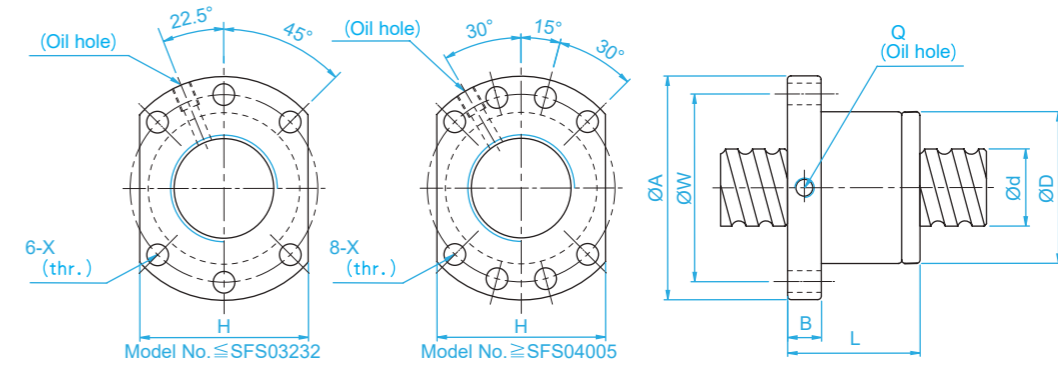
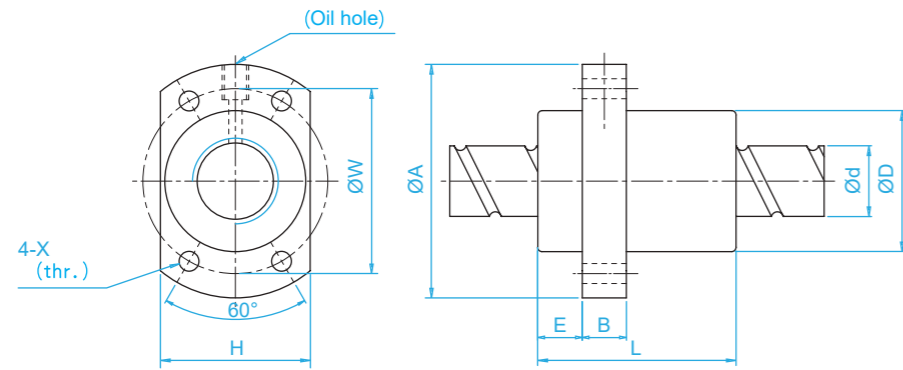

Model	Nomina diameter	Lead	Ball diameter	Nut size										Rated load (Kgf)		Rigidity (Kgf/ μ m)
				D	A	E	B	L	W	H	X	Q	n	Ca	Coa	
SFY1616-3.6	16	16	2.778	32	53	10.1	10	45	42	34	4.5	M6	1.8x2	1073	2551	31
SFY1616-5.6		16	2.778	32	53	10.1	10	61	42	34	4.5	M6	2.8x2	1568	3968	47
SFY2020-3.6	20	20	3.175	39	62	13	10	52	50	41	5.5	M6	1.8x2	1387	3515	37
SFY2020-5.6		20	3.175	39	62	13	10	72	50	41	5.5	M6	2.8x2	2029	5468	56
SFY2525-3.6	25	25	3.969	47	74	15	12	64	60	49	6.6	M6	1.8x2	2074	5494	45
SFY2525-5.6		25	3.969	47	74	15	12	89	60	49	6.6	M6	2.8x2	3032	8546	69
SFY3232-3.6	32	32	4.762	58	92	17	12	78	74	60	9	M6	1.8x2	3021	8690	58
SFY3232-5.6		32	4.762	58	92	17	12	110	74	60	9	M6	2.8x2	4417	13517	88
SFY4040-3.6	40	40	6.35	73	114	19.5	15	99	93	75	11	M6	1.8x2	4831	14062	70
SFY4040-5.6		40	6.35	73	114	19.5	15	139	93	75	11	M6	2.8x2	7065	21874	106
SFY5050-3.6	50	50	7.938	90	135	21.5	20	117	112	92	14	M6	1.8x2	7220	21974	86
SFY5050-5.6		50	7.938	90	135	21.5	20	167	112	92	14	M6	2.8x2	10558	34182	131
Model	Nomina diameter	Lead	Ball diameter	Nut size										Rated load (Kgf)		Rigidity (Kgf/ μ m)
				D	A	E	B	L	W	H	X	Q	n	Ca	Coa	
SFY1632-1.6	16	32	2.778	32	53	10.1	10	42.5	42	34	4.5	M6	0.8x2	493	1116	11
SFY1632-3.6		32	2.778	32	53	10.1	10	74.5	42	34	4.5	M6	1.8x2	989	2511	23
SFY2040-1.6	20	40	3.175	39	62	13	10	48	50	41	5.5	M6	0.8x2	653	1597	15
SFY2040-3.6		40	3.175	39	62	13	10	88	50	41	5.5	M6	1.8x2	1311	3592	30
SFY2550-1.6	25	50	3.969	47	74	15	12	58	60	49	6.6	M6	0.8x2	976	2495	19
SFY2550-3.6		50	3.969	47	74	15	12	108	60	49	6.6	M6	1.8x2	1960	5614	32
SFY3264-1.6	32	64	4.762	58	92	17	12	71	74	60	9	M6	0.8x2	1374	3571	22
SFY3264-3.6		64	4.762	58	92	17	12	135	74	60	9	M6	1.8x2	2759	8441	46
SFY4080-1.6	40	80	6.35	73	114	19.5	15	90	93	75	11	M6	0.8x2	2273	6387	29
SFY4080-3.6		80	6.35	73	114	19.5	15	170	93	75	11	M6	1.8x2	4566	14370	50
SFY50100-1.6	50	100	7.938	90	135	21.5	20	111	112	92	14	M6	0.8x2	3398	9980	35
SFY50100-3.6		100	7.938	90	135	21.5	20	211	112	92	14	M6	1.8x2	6824	22455	72

Model	Nominal diameter	Lead	Ball diameter	Nut size									Rated load (Kgf)		Rigidity (Kgf/ μ m)
				D	A	B	L	W	H	X	Q	n	Ca	Coa	
SFS1205-2.8	12	5	2.5	24	40	10	31	32	30	4.5		2.8x1	661	1316	19
SFS1210-2.8		10	2.5	24	40	10	48.5	32	30	4.5		2.8x1	642	1287	19
SFS1605-3.8	15	5	2.778	28	48	10	38	38	40	5.5	M6	3.8x1	1112	2507	20
SFS1610-2.8		10	2.778	28	48	10	47	38	40	5.5	M6	2.8x1	839	1821	23
SFS1616-1.8		16	2.778	28	48	10	45	38	40	5.5	M6	1.8x1	552	1137	14
SFS1616-2.8		16	2.778	28	48	10	61	38	40	5.5	M6	2.8x1	808	1769	22
SFS1620-1.8		20	2.778	28	48	10	57	38	40	5.5	M6	1.8x1	554	1170	14
SFS2005-3.8	20	5	3.175	36	58	10	40	47	44	6.6	M6	3.8x1	1484	3681	37
SFS2010-3.8		10	3.175	36	58	10	60	47	44	6.6	M6	3.8x1	1516	3833	40
SFS2020-1.8		20	3.175	36	58	10	57	47	44	6.6	M6	1.8x1	764	1758	19
SFS2020-2.8		20	3.175	36	58	10	77	47	44	6.6	M6	2.8x1	1118	2734	29
SFS2505-3.8	25	5	3.175	40	62	10	40	51	48	6.6	M6	3.8x1	1650	4658	43
SFS2510-3.8		10	3.175	40	62	12	62	51	48	6.6	M6	3.8x1	1638	4633	45
SFS2525-1.8		25	3.175	40	62	12	70	51	48	6.6	M6	1.8x1	843	2199	22
SFS2525-2.8		25	3.175	40	62	12	95	51	48	6.6	M6	2.8x1	1232	3421	34
SFS3205-3.8	32	5	3.175	50	80	12	42	65	62	9	M6	3.8x1	1839	6026	51
SFS3210-3.8	31	10	3.969	50	80	13	62	65	62	9	M6	3.8x1	2460	7255	55
SFS3220-2.8		20	3.969	50	80	12	80	65	62	9	M6	2.8x1	1907	5482	43
SFS3232-1.8		32	3.969	50	80	13	84	65	62	9	M6	1.8x1	1257	3426	27
SFS3232-2.8		32	3.969	50	80	13	116	65	62	9	M6	2.8x1	1838	5329	42
SFS4005-3.8	40	5	3.175	63	93	15	45	78	70	9	M8	3.8x1	2018	7589	60
SFS4010-3.8	38	10	6.35	63	93	14	63	78	70	9	M8	3.8x1	5035	13943	67
SFS4020-2.8		20	6.35	63	93	15	82	78	70	9	M8	2.8x1	3959	10715	54
SFS4040-1.8		40	6.35	63	93	15	105	78	70	9	M8	1.8x1	2585	6648	34
SFS4040-2.8		40	6.35	63	93	15	145	78	70	9	M8	2.8x1	3780	10341	52
SFS5005-3.8	50	5	3.175	75	110	15	45	93	85	11	M8	3.8x1	2207	9542	68
SFS5010-3.8	48	10	6.35	75	110	18	68	93	85	11	M8	3.8x1	5638	17852	79
SFS5012-3.8		12	6.35	75	110	18	75	93	85	11	M8	3.8x1	5632	17836	81
SFS5020-3.8		20	6.35	75	110	18	108	93	85	11	M8	3.8x1	5749	18485	87
SFS5050-1.8		50	6.35	75	110	18	125	93	85	11	M8	1.8x1	2946	8749	42
SFS5050-2.8		50	6.35	75	110	18	175	93	85	11	M8	2.8x1	4308	13610	65

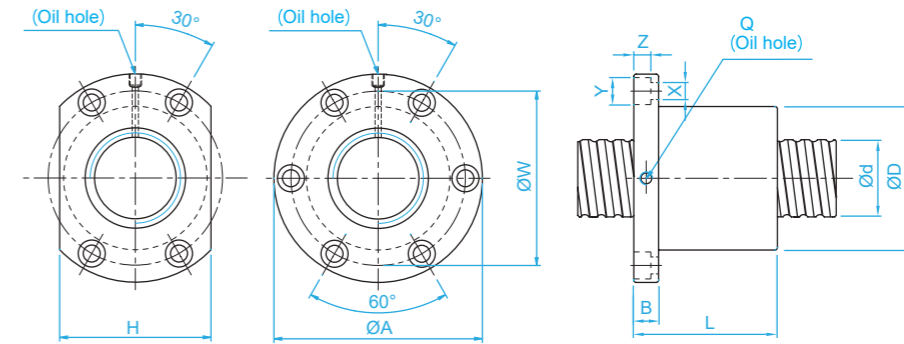
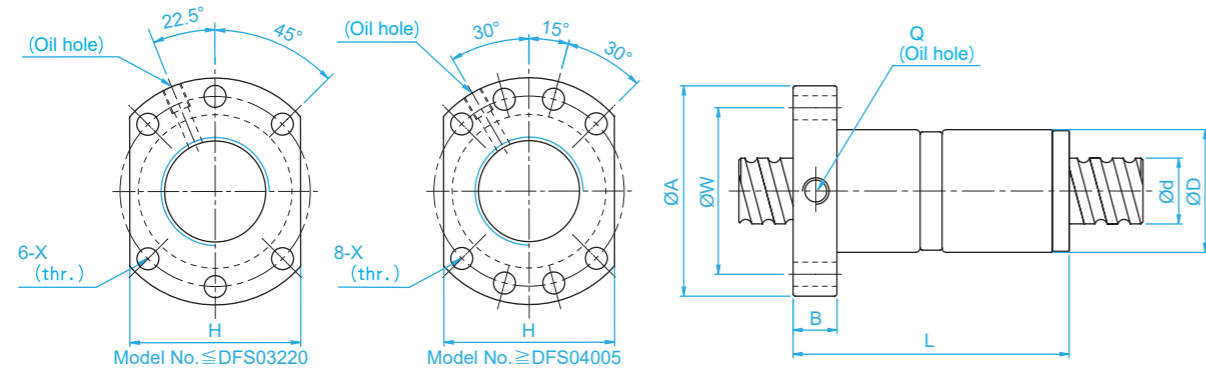

Model	Nominal diameter	Lead	Ball diameter	Nut size									Rated load (Kgf)		Rigidity (Kgf/D μm)
				D	A	B	L	W	H	X	Q	n	Ca	Coa	
DFS1605-3.8	15	5	2.778	28	48	10	73	38	40	5.5	M6	3.8x1	1112	2507	41
DFS1610-2.8		10	2.778	28	48	10	97	38	40	5.5	M6	2.8x1	839	1821	31
DFS2005-3.8	20	5	3.175	36	58	10	75	47	44	6.6	M6	3.8x1	1484	3681	50
DFS2010-3.8		10	3.175	36	58	10	120	47	44	6.6	M6	3.8x1	1516	3833	53
DFS2505-3.8	25	5	3.175	40	62	10	75	51	48	6.6	M6	3.8x1	1650	4658	59
DFS2510-3.8		10	3.175	40	62	12	122	51	48	6.6	M6	3.8x1	1638	4633	61
DFS3205-3.8	32	5	3.175	50	80	12	82	65	62	9	M6	3.8x1	1839	6026	71
DFS3210-3.8	31	10	3.969	50	80	13	122	65	62	9	M6	3.8x1	2460	7255	75
DFS3220-2.8		20	3.969	50	80	12	160	65	62	9	M6	2.8x1	1907	5482	58
DFS4005-3.8	40	5	3.175	63	63	15	85	78	70	9	M8	3.8x1	2018	7589	83
DFS4010-3.8	38	10	6.35	63	63	14	123	78	70	9	M8	3.8x1	5035	13943	91
DFS4020-2.8		20	6.35	63	63	14	162	78	70	9	M8	2.8x1	3959	10715	73
DFS5005-3.8	50	5	3.175	75	75	15	85	93	85	11	M8	3.8x1	2207	9542	96
DFS5010-3.8	48	10	6.35	75	75	18	138	93	85	11	M8	3.8x1	5638	17852	109
DFS5012-3.8		12	6.35	75	75	18	147	93	85	11	M8	3.8x1	5632	17836	110
DFS5020-3.8		20	6.35	75	75	18	218	93	85	11	M8	3.8x1	5749	18485	116

Model	Nominal diameter	Lead	Ball diameter	Nut size										Rated load (Kgf)		Rigidity (Kgf/D μm)	
				D	A	B	L	W	H	X	Y	Z	Q	n	Ca		Coa
SFV1205-2.8	12	5	2.5	30	50	10	42	40	32	4.5	8	4.5	M6	2.8x1	661	1316	19
SFV1210-2.7		10	2.5	30	50	10	53	40	32	4.5	8	4.5	M6	2.7x1	623	1241	18
SFV1510-2.7	15	10	3.175	34	58	10	57	45	34	5.5	9.5	5.5	M6	2.7x1	972	2020	23
SFV1604-3.8	16	4	2.381	34	57	11	45	45	34	5.5	9.5	5.5	M6	3.8x1	931	2285	31
SFV1605-4.8		5	3.175	40	63	11	58	51	42	5.5	9.5	5.5	M6	4.8x1	1614	3662	40
SFV1610-2.7		10	3.175	40	63	11	56	51	42	5.5	9.5	5.5	M6	2.7x1	1008	2161	24
SFV2004-4.8	20	4	2.381	40	60	10	50	50	40	4.5	8	4	M6	4.8x1	1247	3584	45
SFV2005-4.8		5	3.175	44	67	11	57	55	52	5.5	9.5	5.5	M6	4.8x1	1814	4650	47
SFV2010-2.7		10	3.969	46	74	13	57	59	46	6.6	11	6.5	M6	2.7x1	1518	3398	30
SFV2020-1.8	25	20	3.175	46	74	13	70	59	46	6.6	11	6.5	M6	1.8x1	764	1758	19
SFV2505-4.8		5	3.175	50	73	11	55	61	52	5.5	9.5	5.5	M8	4.8x1	2017	5884	56
SFV2506-4.8		6	3.969	53	76	11	62	64	58	5.5	9.5	5.5	M6	4.8x1	2711	7268	58
SFV2508-4.8		8	4.762	56	85	13	70	71	64	6.5	11	6.5	M6	4.8x1	3466	8776	61
SFV2510-2.7		10	6.35	68	102	15	70	84	82	9	14	8.5	M8	2.7x1	3040	8547	37
SFV2525-1.8	32	25	3.175	50	73	13	83	61	52	5.5	9.5	5.5	M8	1.8x1	843	2199	22
SFV3204-4.8		4	2.381	54	81	12	50	67	64	6.6	11	6.5	M6	4.8x1	1517	5806	62
SFV3205-4.8		5	3.175	58	85	12	56	71	64	6.6	11	6.5	M8	4.8x1	2249	7612	66
SFV3206-4.8		6	3.969	62	89	12	60	75	68	6.6	11	6.5	M8	4.8x1	3079	9575	70
SFV3208-4.8		8	4.762	66	100	15	75	82	76	9	14	8.5	M8	4.8x1	3962	11547	74
SFV3210-4.8		10	6.35	74	108	15	96	90	82	9	14	9	M8	4.8x1	5620	14649	76
SFV3220-2.7		20	6.35	74	108	16	100	90	82	9	14	8.5	M8	2.7x1	3509	8644	46
SFV4005-4.8	40	5	3.175	67	101	15	59	83	72	9	14	8.5	M8	4.8x1	2468	9586	76
SFV4010-4.8		10	6.35	82	124	18	100	102	94	11	17.5	11	M8	4.8x1	6316	18600	90
SFV4020-2.7		20	6.35	82	124	18	100	102	90	11	17.5	11	M8	2.7x1	3935	10893	56
SFV5005-4.8	50	5	3.175	80	114	15	60	96	82	9	14	8.5	M8	4.8x1	2698	12053	87
SFV5010-4.8		10	6.35	93	135	16	93	113	98	11	17.5	11	M8	4.8x1	7023	23537	106
SFV5020-2.7		20	9.525	105	152	28	121	128	110	14	20	13	M8	2.7x1	7336	19700	68
SFV6310-4.8	63	10	6.35	108	154	22	105	130	110	14	20	13	M8	4.8x1	7860	30430	126
SFV6320-2.7		20	9.525	122	180	28	120	150	130	18	26	17.5	M8	2.7x1	8162	24741	80
SFV8010-4.8	80	10	6.35	130	176	22	105	152	132	14	20	13	M8	4.8x1	8593	38344	145
SFV8020-4.8		20	9.525	143	204	28	180	172	148	18	26	18	M8	4.8x1	15103	57296	168
SFV8020-7.6		20	9.525	143	204	28	240	172	148	18	26	18	M8	3.8x2	22423	90719	260

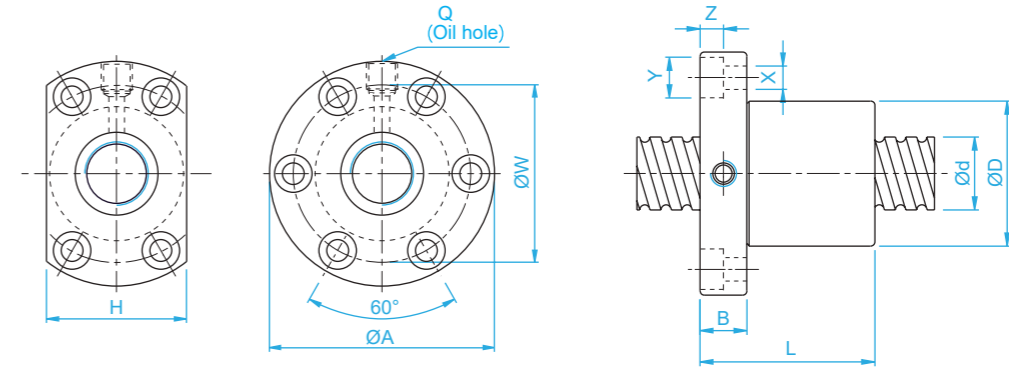
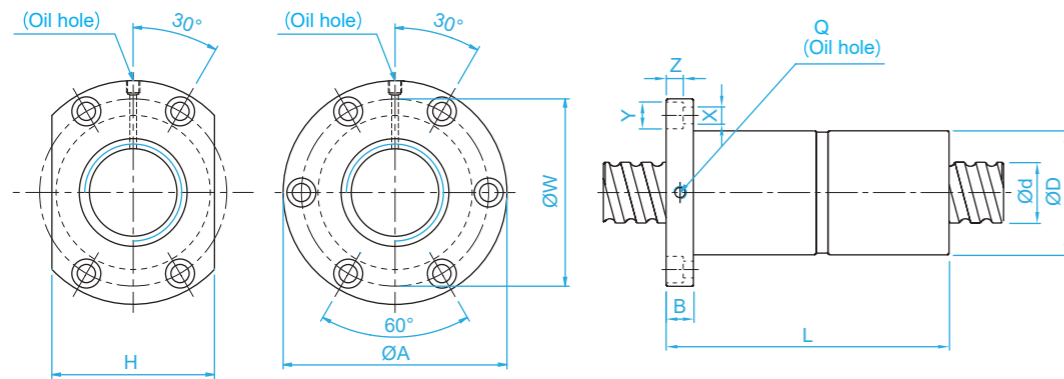

Model	Nominal diameter	Lead	Ball diameter	Nut size											Rated load (Kgf)		Rigidity (Kgf/D μm)
				D	A	B	L	W	H	X	Y	Z	Q	n	Ca	Coa	
DFV1510-2.7	15	10	3.175	34	58	10	107	45	34	5.5	9.5	5.5	M6	2.7x1	972	2020	30
DFV1604-3.8	16	4	2.381	34	57	11	89	45	34	5.5	9.5	5.5	M6	3.8x1	931	2285	42
DFV1605-4.8		5	3.175	40	63	11	113	51	42	5.5	9.5	5.5	M6	4.8x1	1614	3662	53
DFV1610-2.7		10	3.175	40	63	11	106	51	42	5.5	9.5	5.5	M6	2.7x1	1008	2161	32
DFV2004-4.8	20	4	2.381	40	60	10	94	50	40	4.5	8	4	M6	4.8x1	1247	3584	61
DFV2005-4.8		5	3.175	44	67	11	112	55	52	5.5	9.5	5.5	M6	4.8x1	1814	4650	63
DFV2010-2.7		10	3.969	46	74	13	117	59	46	6.6	11	6.5	M6	2.7x1	1518	3398	40
DFV2505-4.8	25	5	3.175	50	73	11	105	61	52	5.5	9.5	5.5	M8	4.8x1	2017	5884	75
DFV2506-4.8		6	3.969	53	76	11	116	64	58	5.5	9.5	5.5	M6	4.8x1	2711	7268	78
DFV2508-4.8		8	4.762	56	85	13	134	71	64	6.5	11	6.5	M6	4.8x1	3466	8776	82
DFV2510-2.7		10	6.35	68	102	15	130	84	82	9	14	8.5	M8	2.7x1	3040	6547	49
DFV3204-4.8	32	4	2.381	54	81	12	94	67	64	6.6	11	6.5	M6	4.8x1	1517	5806	85
DFV3205-4.8		5	3.175	58	85	12	106	71	64	6.6	11	6.5	M8	4.8x1	2249	7612	90
DFV3206-4.8		6	3.969	62	89	12	114	75	68	6.6	11	6.5	M8	4.8x1	3079	9575	95
DFV3208-4.8		8	4.762	66	100	15	139	82	76	9	14	8.5	M8	4.8x1	3962	11547	100
DFV3210-4.8		10	6.35	74	108	15	186	90	82	9	14	9	M8	4.8x1	5620	14649	101
DFV3220-2.7		20	6.35	74	108	16	200	90	82	9	14	8.5	M8	2.7x1	3509	8644	61
DFV4005-4.8	40	5	3.175	67	101	15	109	83	72	9	14	8.5	M8	4.8x1	2468	9586	105
DFV4010-4.8		10	6.35	82	124	18	188	102	94	11	17.5	11	M8	4.8x1	6316	18600	121
DFV4020-2.7		20	6.35	82	124	18	200	102	90	11	17.5	11	M8	2.7x1	3935	10893	74
DFV5005-4.8	50	5	3.175	80	114	15	115	96	82	9	14	8.5	M8	4.8x1	2698	12053	122
DFV5010-4.8		10	6.35	93	135	16	173	113	98	11	17.5	11	M8	4.8x1	7023	23537	144
DFV5020-2.7		20	9.525	105	152	28	221	128	110	14	20	13	M8	2.7x1	7336	19700	90
DFV6310-4.8	63	10	6.35	108	154	22	195	130	110	14	20	13	M8	4.8x1	7860	30430	172
DFV6320-2.7		20	9.525	122	180	28	220	150	130	18	26	17.5	M8	2.7x1	8162	24741	107
DFV8010-4.8	80	10	6.35	130	176	22	195	152	132	14	20	13	M8	4.8x1	8593	38344	201
DFV8020-4.8		20	9.525	143	204	28	340	172	148	18	26	18	M8	4.8x1	15103	57296	226
DFV8020-7.6		20	9.525	143	204	28	460	172	148	18	26	18	M8	3.8x2	22423	90719	351

Model	Nominal diameter	Lead	Ball diameter	Nut size											Rated load (Kgf)		Rigidity (Kgf/D μm)
				D	A	B	L	W	H	X	Y	Z	Q	n	Ca	Coa	
SFI1604-4	16	4	2.381	30	49	10	45	39	34	4.5	8	4.5	M6	1x4	973	2406	32
SFI1605-4		5	3.175	30	49	10	50	39	34	4.5	8	4.5	M6	1x4	1380	3052	33
SFI1610-3		10	3.175	34	58	10	57	45	34	5.5	9.5	5.5	M6	1x3	1103	2401	27
SFI2004-4	20	4	2.381	34	57	11	46	45	40	5.5	9.5	5.5	M6	1x4	1066	2987	37
SFI2005-4		5	3.175	34	57	11	51	45	40	5.5	9.5	5.5	M6	1x4	1551	3875	39
SFI2504-4	25	4	2.381	40	63	11	46	51	46	5.5	9.5	5.5	M6	1x4	1180	3795	43
SFI2505-4		5	3.175	40	63	11	51	51	46	5.5	9.5	5.5	M8	1x4	1724	4904	45
SFI2510-4		10	4.762	46	72	12	85	58	52	6.5	11	6.5	M6	1x4	2954	7295	51
SFI3204-4	32	4	2.381	46	72	12	47	58	52	6.5	11	6.5	M6	1x4	1296	4838	49
SFI3205-4		5	3.175	46	72	12	52	58	52	6.5	11	6.5	M8	1x4	1922	6343	52
SFI3210-4		10	6.35	54	88	15	90	70	62	9	14	8.5	M8	1x4	4805	12208	62
SFI4005-4	40	5	3.175	56	90	15	55	72	64	9	14	8.5	M8	1x4	2110	7988	59
SFI4010-4		10	6.35	62	104	18	93	82	70	11	17.5	11	M8	1x4	5399	15500	72
SFI5010-4	50	10	6.35	72	114	18	93	92	82	11	17.5	11	M8	1x4	6004	19614	83
SFI6310-4	63	10	6.35	85	131	22	98	107	95	14	20	13	M8	1x4	6719	25358	95
SFI8010-4	80	10	6.35	105	150	22	98	127	115	14	20	13	M8	1x4	7346	31953	109

Above models can be made left-hand

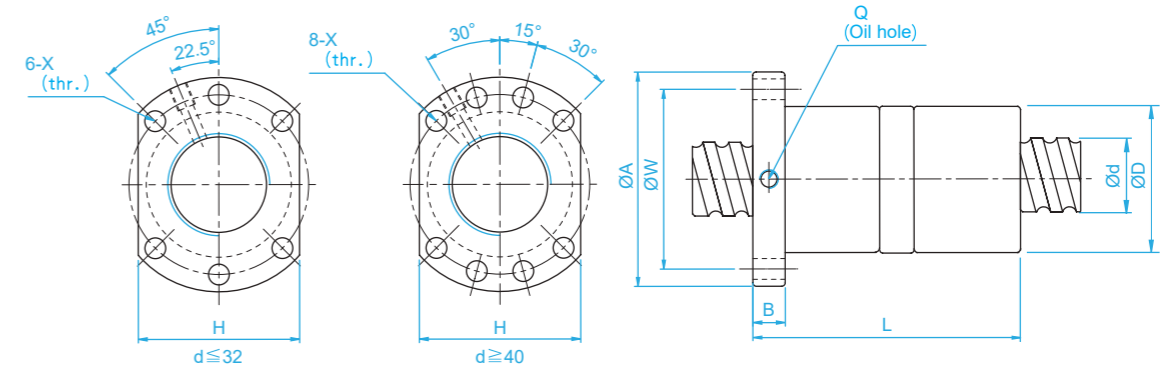
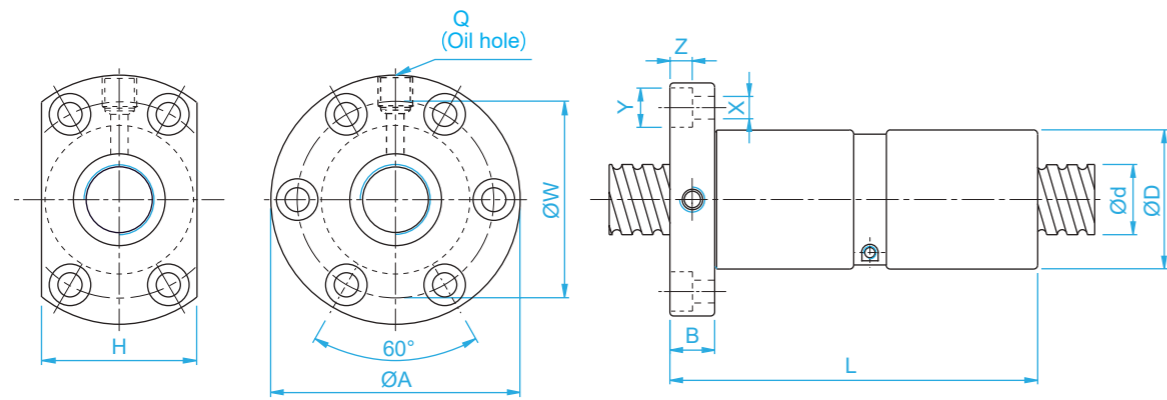

Model	Nominal diameter	Lead	Ball diameter	Nut size											Rated load (Kgf)		Rigidity (Kgf/D μm)
				D	A	B	L	W	H	X	Y	Z	Q	n	Ca	Coa	
DFI1604-4	16	4	2.381	30	49	10	80	39	34	4.5	8	4.5	M6	1x4	973	2406	44
DFI1605-4		5	3.175	30	49	10	100	39	34	4.5	8	4.5	M6	1x4	1380	3052	44
DFI2004-4	20	4	2.381	34	57	11	80	45	40	5.5	9.5	5.5	M6	1x4	1066	2987	51
DFI2005-4		5	3.175	34	57	11	101	45	40	5.5	9.5	5.5	M6	1x4	1551	3875	52
DFI2504-4	25	4	2.381	40	63	11	80	51	46	5.5	9.5	5.5	M6	1x4	1180	3795	60
DFI2505-4		5	3.175	40	63	11	101	51	46	5.5	9.5	5.5	M8	1x4	1724	4904	62
DFI2510-4		10	4.762	46	72	12	145	58	52	6.5	11	6.5	M6	1x4	2954	7295	68
DFI3204-4	32	4	2.381	46	72	12	80	58	52	6.5	11	6.5	M6	1x4	1296	4838	69
DFI3205-4		5	3.175	46	72	12	102	58	52	6.5	11	6.5	M8	1x4	1922	6343	72
DFI3210-4		10	6.35	54	88	15	162	70	62	9	14	8.5	M8	1x4	4805	12208	83
DFI4005-4	40	5	3.175	56	90	15	105	72	64	9	14	8.5	M8	1x4	2110	7988	84
DFI4010-4		10	6.35	62	104	18	165	82	70	11	17.5	11	M8	1x4	5399	15500	99
DFI5010-4	50	10	6.35	72	114	18	171	92	82	11	17.5	11	M8	1x4	6004	19614	115
DFI6310-4	63	10	6.35	85	131	22	182	107	95	14	20	13	M8	1x4	6719	25358	135
DFI8010-4	80	10	6.35	105	150	22	182	127	115	14	20	13	M8	1x4	7346	31953	156

Above models can be made left-hand

Model	Nominal diameter	Lead	Ball diameter	Nut size									Rated load (Kgf)		Rigidity (Kgf/D μm)
				D	A	B	L	W	H	X	Q	n	Ca	Coa	
DFU1604-4	16	4	2.381	28	48	10	80	38	40	5.5	M6	1x4	973	2406	43
DFU1605-4		5	3.175	28	48	10	100	38	40	5.5	M6	1x4	1380	3052	44
DFU1610-3		10	3.175	28	48	10	118	38	40	5.5	M6	1x3	1103	2401	35
DFU2004-4	20	4	2.381	36	58	10	80	47	44	6.6	M6	1x4	1066	2987	51
DFU2005-4		5	3.175	36	58	10	101	47	44	6.6	M6	1x4	1551	3875	53
DFU2504-4	25	4	2.381	40	62	10	80	51	48	6.6	M6	1x4	1180	3795	60
DFU2505-4		5	3.175	40	62	10	101	51	48	6.6	M6	1x4	1724	4904	62
DFU2506-4		6	3.969	40	62	10	105	51	48	6.6	M6	1x4	2318	6057	64
DFU2508-4		8	4.762	40	62	10	120	51	48	6.6	M6	1x4	2963	7313	67
DFU2510-4	10	4.762	40	62	12	145	51	48	6.6	M6	1x4	2954	7295	67	
DFU3204-4	32	4	2.681	50	80	12	80	65	62	9	M6	1x4	1296	4838	71
DFU3205-4		5	3.175	50	80	12	102	65	62	9	M6	1x4	1922	6343	74
DFU3206-4		6	3.969	50	80	12	105	65	62	9	M6	1x4	2632	7979	78
DFU3208-4		8	4.762	50	80	12	122	65	62	9	M6	1x4	3387	9622	82
DFU3210-4	10	6.35	50	80	12	162	65	62	9	M6	1x4	4805	12208	82	
DFU4005-4	40	5	3.175	63	93	14	105	78	70	9	M8	1x4	2110	7988	87
DFU4006-4		6	3.969	63	93	14	108	78	70	9	M6	1x4	2873	9913	91
DFU4008-4		8	4.762	63	93	14	132	78	70	9	M6	1x4	3712	11947	96
DFU4010-4		10	6.35	63	93	14	165	78	70	9	M8	1x4	5399	15500	99
DFU5010-4	50	10	6.35	75	110	16	171	93	85	11	M8	1x4	6004	19614	117
DFU5020-4		20	7.144	75	110	16	280	93	85	11	M8	1x4	7142	22588	126
DFU6310-4	63	10	6.35	90	125	18	182	108	95	11	M8	1x4	6719	25358	139
DFU6320-4		20	9.525	95	135	20	290	115	100	13.5	M8	1x4	11444	36653	152
DFU8010-4	80	10	6.35	105	145	20	182	125	110	13.5	M8	1x4	7346	31953	156
DFU8020-4		20	9.525	125	165	25	295	145	130	13.5	M8	1x4	12911	47747	187
DFU10020-4	100	20	9.525	150	202	30	340	170	155	17.5	M8	1x4	14303	60698	222

Above models can be made left-hand

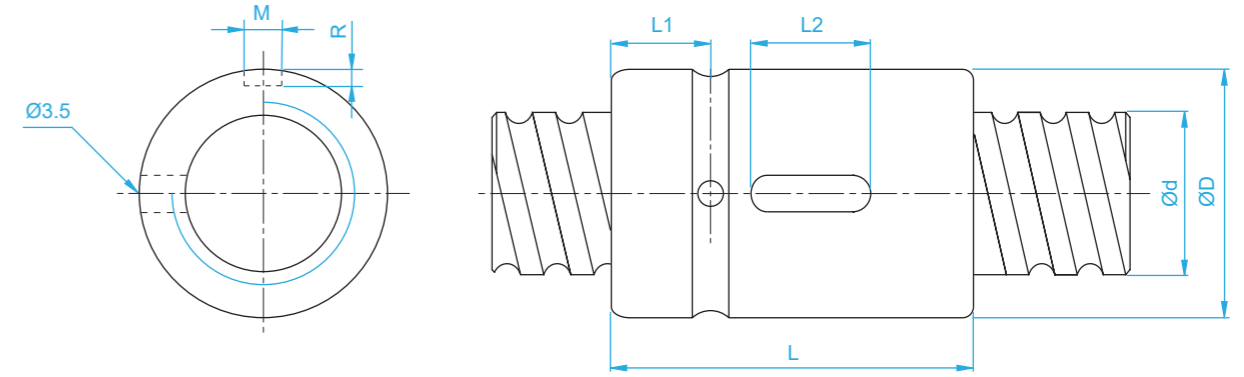
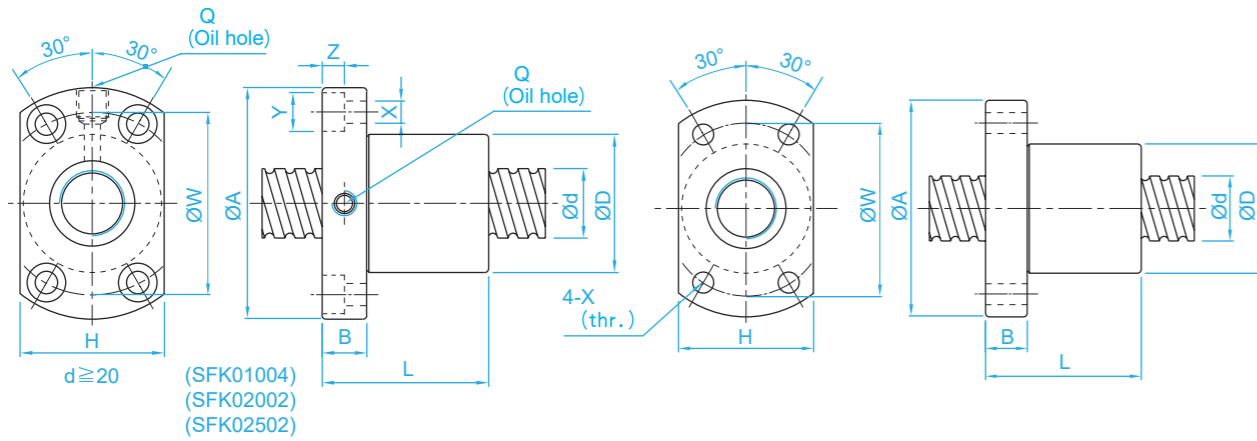

Model	Nominal diameter	Lead	Ball diameter	Nut size											Rated load (Kgf)		Rigidity (Kgf/D μm)
				D	A	B	L	W	H	X	Y	Z	Q	n	Ca	Coa	
SFK0401	4	1	0.8	10	20	3	12	15	14	2.9	-	-	-	1x2	64	97	5
SFK0601	6	1	0.8	12	24	3.5	15	18	16	3.4	-	-	-	1x3	111	224	9
SFK0801	8	1	0.8	14	27	4	16	21	18	3.4	-	-	-	1x4	161	403	14
SFK0802		2	1.2	14	27	4	16	21	18	3.4	-	-	-	1x3	222	458	13
SFK0802.5		2.5	1.2	16	29	4	26	23	20	3.4	-	-	-	1x3	221	457	13
SFK1002	10	2	1.2	18	35	5	28	27	22	4.5	-	-	-	1x3	243	569	15
SFK1004		4	2	26	46	10	34	36	28	4.5	8	4.5	M6	1x3	468	905	17
SFK1202	12	2	1.2	20	37	5	28	29	24	4.5	-	-	-	1x4	334	906	22
SFK1402	14	2	1.2	21	40	6	23	31	26	5.5	-	-	-	1x4	354	1053	24
SFK1602	16	2	1.2	25	43	10	40	35	29	5.5	-	-	M6	1x4	373	1200	26
SFK2002	20	2	1.2	50	80	15	55	65	68	6.5	10.5	6	M6	1x6	581	2284	48
SFK2502	25	2	1.2	50	80	13	43	65	68	6.5	10.5	6	M6	1x5	540	2381	46

Above models can be made left-hand

Model	Nominal diameter	Lead	Ball diameter	Nut size											Rated load (Kgf)		Rigidity (Kgf/D μm)
				D	A	B	L	W	H	X	Y	Z	Q	n	Ca	Coa	
XSUR1204T3D-02	12	4	2.5	24	40	6	28	32	25	3.5	-	-	-	1x3	454	722	-
XSUR1205T3D-00		5	2.5	22	37	8	39	29	24	4.5	-	-	-	1x3	675	1316	17

Model	Nominal diameter	Lead	Ball diameter	Nut size							Rated load (Kgf)		Rigidity (Kgf/D μm)
				D	L	L1	L2	M	R	n	Ca	Coa	
SCI1604-4	16	4	2.381	30	40	9	15	3	1.5	1x4	973	2406	32
SCI1605-4		5	3.175	30	45	9	20	5	3	1x4	1380	3052	33
SCI2004-4	20	4	2.381	34	40	9	15	3	1.5	1x4	1066	2987	37
SCI2005-4		5	3.175	34	45	9	20	5	3	1x4	1551	3875	39
SCI2504-4	25	4	2.381	40	40	9	15	3	1.5	1x4	1180	3795	43
SCI2505-4		5	3.175	40	45	9	20	5	3	1x4	1724	4904	45
SCI2510-4		10	4.762	46	85	13	30	5	3	1x4	2954	7295	51
SCI3204-4	32	4	2.381	46	40	9	15	3	1.5	1x4	1296	4838	49
SCI3205-4		5	3.175	46	45	9	20	5	3	1x4	1922	6343	52
SCI3210-4		10	6.35	54	85	13	30	5	3	1x4	4805	12208	62
SCI4005-4	40	5	3.175	56	45	9	20	5	3	1x4	2110	7988	59
SCI4010-4		10	6.35	62	85	13	30	5	3	1x4	5399	15500	72
SCI5010-4	50	10	6.35	72	85	13	30	5	3	1x4	6004	19614	83
SCI6310-4	63	10	6.35	85	85	13	30	6	3.5	1x4	6719	25358	95
SCI8010-4	80	10	6.35	105	85	13	30	8	4.5	1x4	7346	31953	109

Above models can be made left-hand

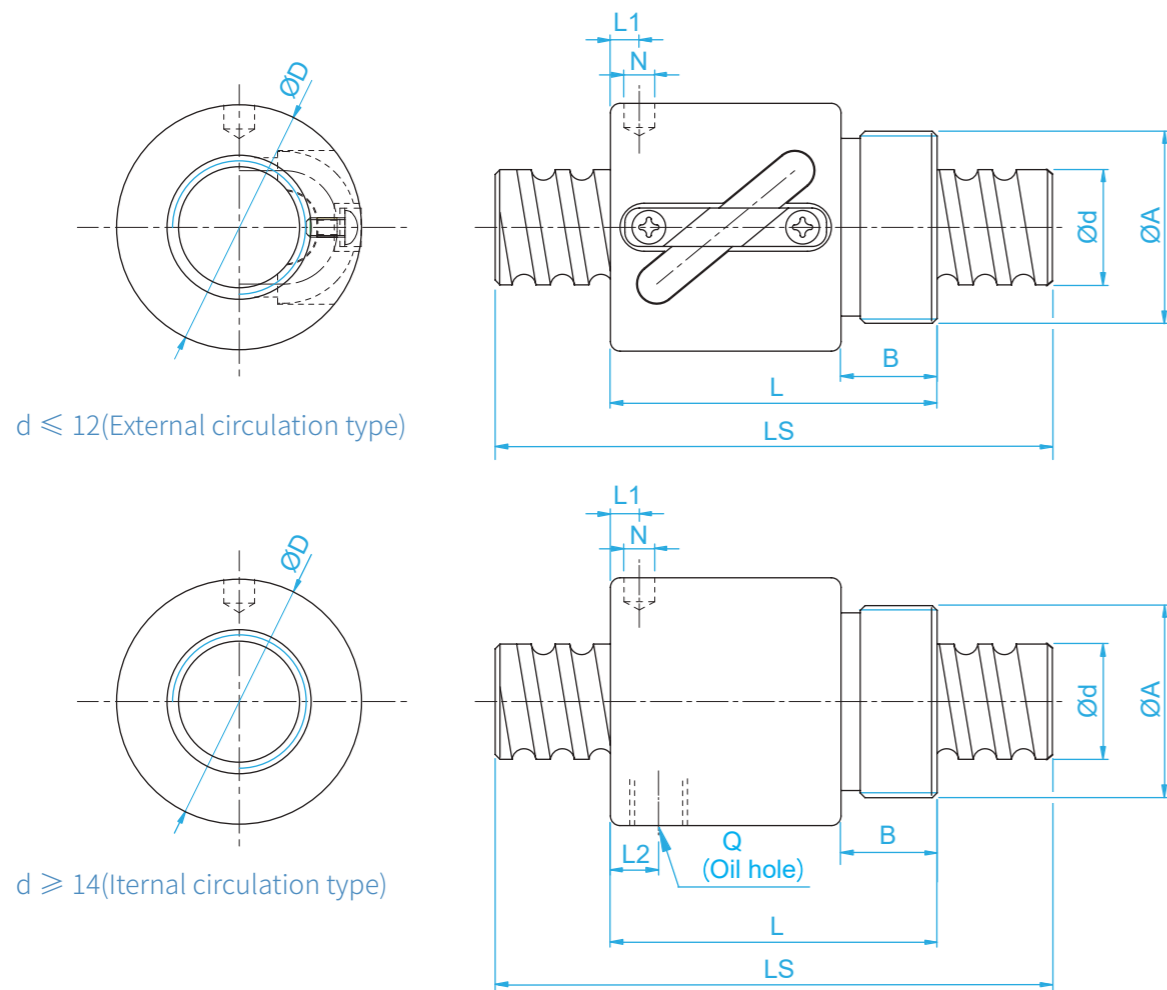

Model	Nominal diameter	Lead	Ball diameter	Nut size								Rated load (Kgf)		Rigidity (Kgf/D μ m)	
				D	A	B	L	L1	N	L2	Q	n	Ca		Coa
BSHR0802.5-2.5	8	2.5	1.2	17.5	M15x1P	7.5	23.5	10	3	-	-	2.5x1	189	381	11
BSHR1002-3.5	10	2	1.2	19.5	M17x1P	7.5	22	3	3.2	-	-	3.5x1	277	664	17
BSHR1004-2.5		4	2	25	M20x1P	10	34	3	3	-	-	2.5x1	400	754	14
BSHR1204-3.5	12	4	2.5	25.5	M20x1P	10	34	13	3	-	-	3.5x1	804	1649	23
BSHR1205-3.5		5	2.5	25.5	M20x1P	10	39	16.25	3	-	-	3.5x1	801	1644	24
BSHR1404-3	14	4	2.5	32.1	M25x1.5P	10	35	11	3	-	-	1x3	748	1609	26
BSHR1604-3	16	4	2.381	29	M22x1.5P	8	32	4	3.2	-	-	1x3	759	1804	24
BSHR1605-3		5	3.175	32.5	M26x1.5P	12	42	19.25	3	-	-	1x3	1077	2289	25
BSHR1610-2		10	3.175	32	M26x1.5P	12	50	3	4	3	M4	1x2	675	1316	14
BSHR2005-3	20	5	3.175	38	M35x1.5P	15	45	20.3	3	-	-	1x3	1211	2906	30
BSHR2505-4	25	5	3.175	43	M40x1.5P	19	69	32.11	3	8	M6	1x4	1724	4904	37
BSHR2510-4		10	4.762	43	M40x1.5P	19	84	8	6	8	M6	1x4	2954	7295	41

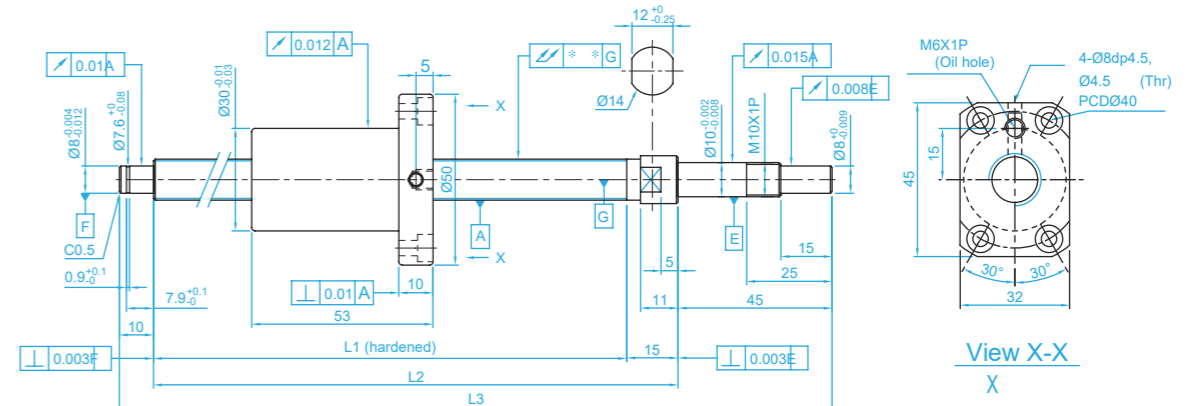

XSVR1210-01 Series specification

Ball center	12.85
Ball diameter	2.5
Lead	10
Ball cycles	2.7x1
Thread direct	13.91°
Thread direct	R
Spring Force	0.1~0.2kg
Preload amount	25kgf
Dynamic load	623
Static load	1241
Precision	0.018

Stroke	Model	Shaft length			Axis deviation
		L1	L2	L3	
100	XSVR1210B1DGC5-230-P1	160	175	230	0.035
150	XSVR1210B1DGC5-280-P1	210	225	280	0.035
250	XSVR1210B1DGC5-380-P1	310	325	380	0.050
350	XSVR1210B1DGC5-480-P1	410	425	480	0.050
450	XSVR1210B1DGC5-580-P1	510	525	580	0.075

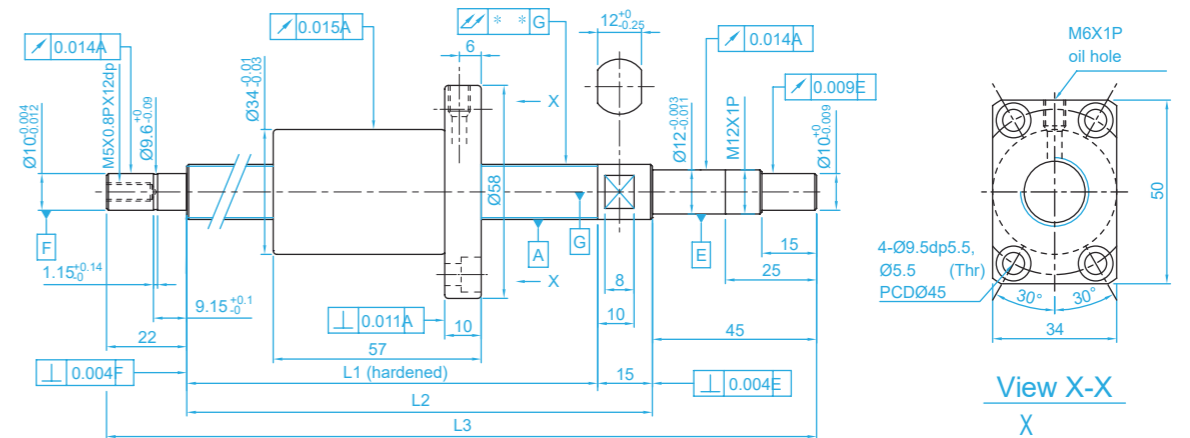

XSVR1510-00 Series specification

Ball center	15.5
Ball diameter	3.175
Lead	10
Ball cycles	2.7x1
Thread direct	11.6°
Thread direct	R
Spring Force	0.1~0.3kg
Preload amount	38kgf
Dynamic load	933
Static load	1885
Precision	0.018

Stroke	Model	Shaft length			Axis deviation
		L1	L2	L3	
100	XSVR1510B1DGC5-271-P1	189	204	271	0.025
150	XSVR1510B1DGC5-321-P1	239	254	321	0.035
200	XSVR1510B1DGC5-371-P1	289	304	371	0.035
250	XSVR1510B1DGC5-421-P1	339	354	421	0.040
300	XSVR1510B1DGC5-471-P1	389	404	471	0.040
350	XSVR1510B1DGC5-521-P1	439	454	521	0.050
400	XSVR1510B1DGC5-571-P1	489	504	571	0.050
450	XSVR1510B1DGC5-621-P1	539	554	621	0.050
500	XSVR1510B1DGC5-671-P1	589	604	671	0.065
550	XSVR1510B1DGC5-721-P1	639	654	721	0.065
600	XSVR1510B1DGC5-771-P1	689	704	771	0.065
700	XSVR1510B1DGC5-871-P1	789	804	871	0.085
800	XSVR1510B1DGC5-971-P1	889	904	971	0.085

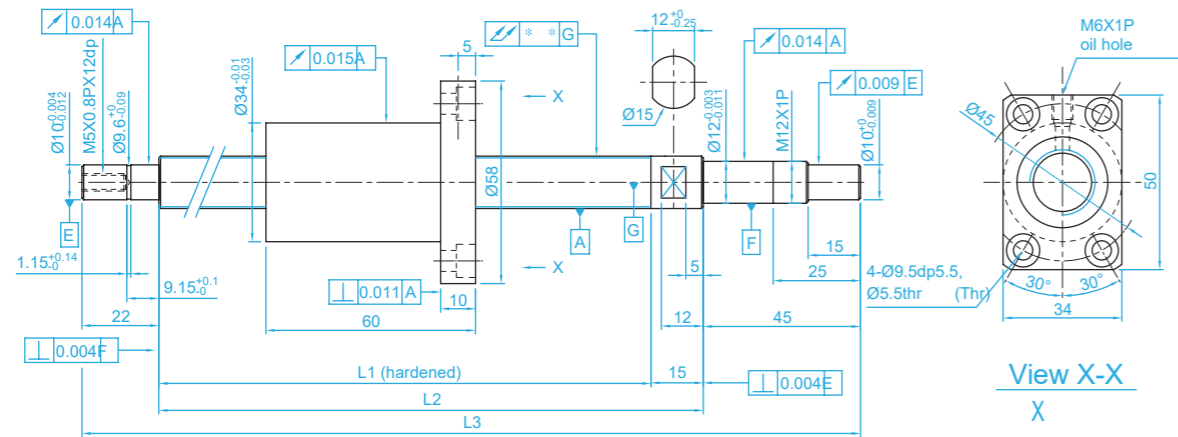

XSVR1520-01
Series specification

Ball center	15.5
Ball diameter	3.175
Lead	20
Ball cycles	1.8x1
Thread direct	22.33°
Thread direct	R
Spring Force	0.1~0.3kg
Preload amount	38kgf
Dynamic load	638
Static load	1266
Precision	0.018

Stroke	Model	Shaft length			Axis deviation
		L1	L2	L3	
100	XSVR1520A1DGC5-271-P1	189	204	271	0.025
150	XSVR1520A1DGC5-321-P1	239	254	321	0.035
200	XSVR1520A1DGC5-371-P1	289	304	371	0.035
250	XSVR1520A1DGC5-421-P1	339	354	421	0.040
300	XSVR1520A1DGC5-471-P1	389	404	471	0.040
350	XSVR1520A1DGC5-521-P1	439	454	521	0.050
400	XSVR1520A1DGC5-571-P1	489	504	571	0.050
450	XSVR1520A1DGC5-621-P1	539	554	621	0.050
500	XSVR1520A1DGC5-671-P1	589	604	671	0.065
550	XSVR1520A1DGC5-721-P1	639	654	721	0.065
600	XSVR1520A1DGC5-771-P1	689	704	771	0.065
700	XSVR1520A1DGC5-871-P1	789	804	871	0.085
800	XSVR1520A1DGC5-971-P1	889	904	971	0.085

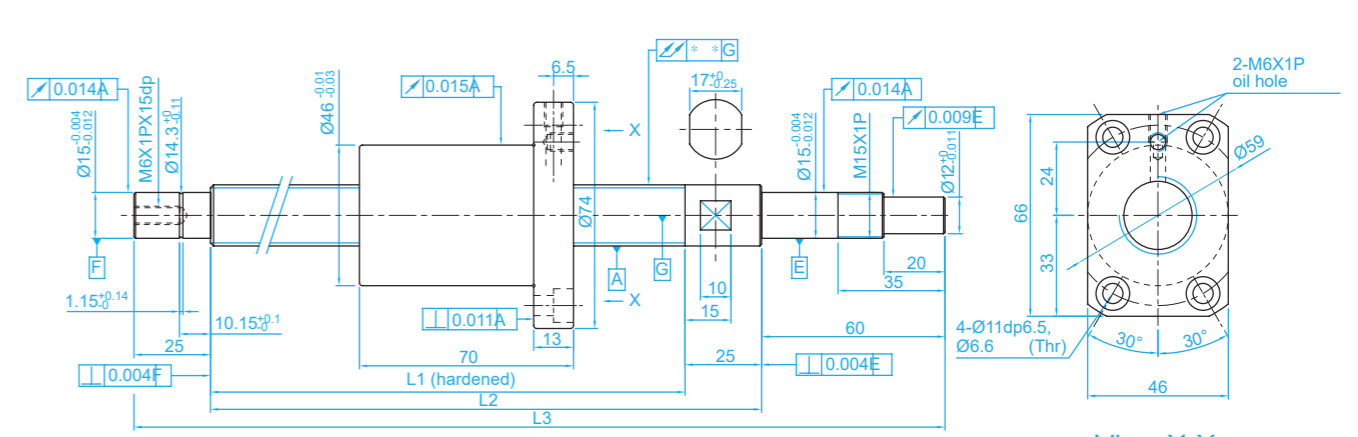

XSVR2020-00
Series specification

Ball center	20.75
Ball diameter	3.175
Lead	20
Ball cycles	1.8x1
Thread direct	17.05°
Thread direct	R
Spring Force	0.1~0.3kg
Preload amount	31kgf
Dynamic load	764
Static load	1758
Precision	0.018

Stroke	Model	Shaft length			Axis deviation
		L1	L2	L3	
200	XSVR2020A1DGC5-399-P1	289	314	399	0.035
300	XSVR2020A1DGC5-499-P1	389	414	499	0.040
400	XSVR2020A1DGC5-599-P1	489	514	599	0.050
500	XSVR2020A1DGC5-699-P1	589	614	699	0.065
600	XSVR2020A1DGC5-799-P1	689	714	799	0.065
700	XSVR2020A1DGC5-899-P1	789	814	899	0.085
800	XSVR2020A1DGC5-999-P1	889	914	999	0.085
900	XSVR2020A1DGC5-1099-P1	989	1014	1099	0.110
1000	XSVR2020A1DGC5-1199-P1	1089	1114	1199	0.110

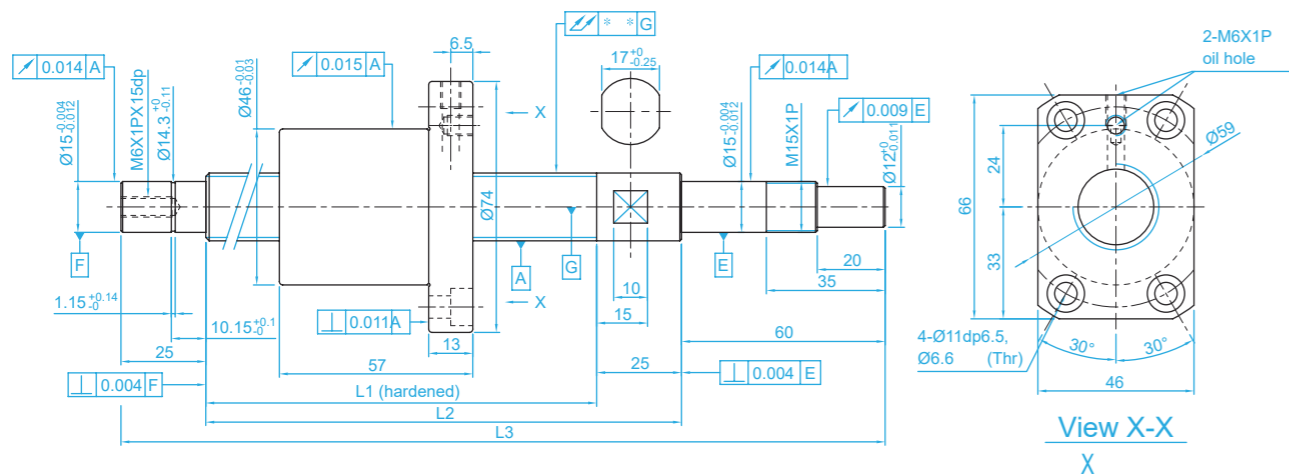

XSVR2010-00
Series specification

Ball center	21.35
Ball diameter	3.969
Lead	10
Ball cycles	2.7x1
Thread direct	8.48°
Thread direct	R
Spring Force	0.1~0.3kg
Preload amount	43kgf
Dynamic load	1518
Static load	3398
Precision	0.018

Stroke	Model	Shaft length			Axis deviation
		L1	L2	L3	
200	XSVR2010B1DGC5-399-P1	289	314	399	0.035
300	XSVR2010B1DGC5-499-P1	389	414	499	0.040
400	XSVR2010B1DGC5-599-P1	489	514	599	0.050
500	XSVR2010B1DGC5-699-P1	589	614	699	0.065
600	XSVR2010B1DGC5-799-P1	689	714	799	0.065
700	XSVR2010B1DGC5-899-P1	789	814	899	0.085
800	XSVR2010B1DGC5-999-P1	889	914	999	0.085
900	XSVR2010B1DGC5-1099-P1	989	1014	1099	0.110
1000	XSVR2010B1DGC5-1199-P1	1089	1114	1199	0.110

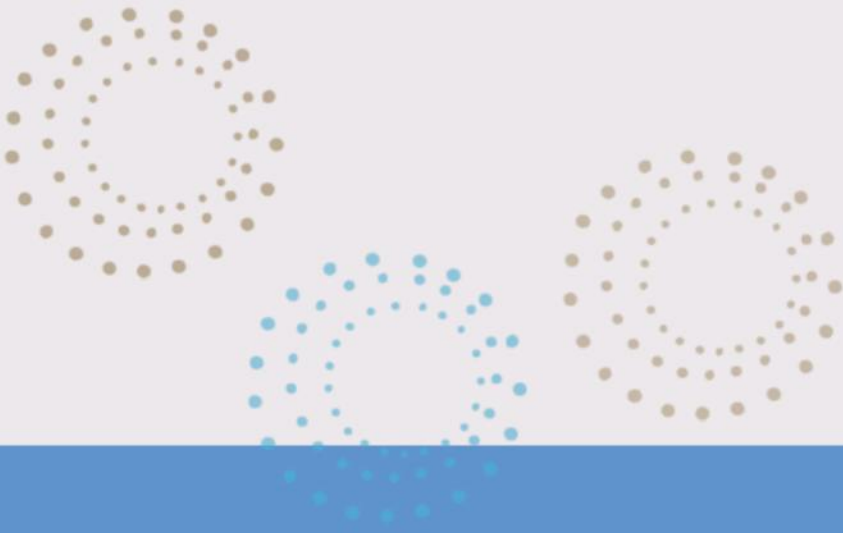

SCREW TECHNOLOGY CO.,LTD.

Add:No 988,Wsong Road,Wuzhong Disrict,Suzhou,China

Tel:+86-0512-66903936,+86-0512-65073935

E-mail:IMD@screwtech.cn

Web:<http://www.screw-tech.com/>

V-4.0
20210608